

# Margin Allocation for 500GB Holographic Memory System using Monocular Architecture

**Toshiki Ishii , Ken-ichi Shimada**

*Hitachi, Ltd.*

**Steve Hughes , Alan Hoskins , Kevin Curtis**

*InPhase Technologies, Inc.*



**HITACHI**  
Inspire the Next

1. Introduction
2. Requirements to signal metric
3. Experimental setup
4. Results
5. Conclusion

1. Introduction
2. Requirements to signal metric
3. Experimental setup
4. Results
5. Conclusion

# 1.1 Monocular Architecture

(a) Professional system

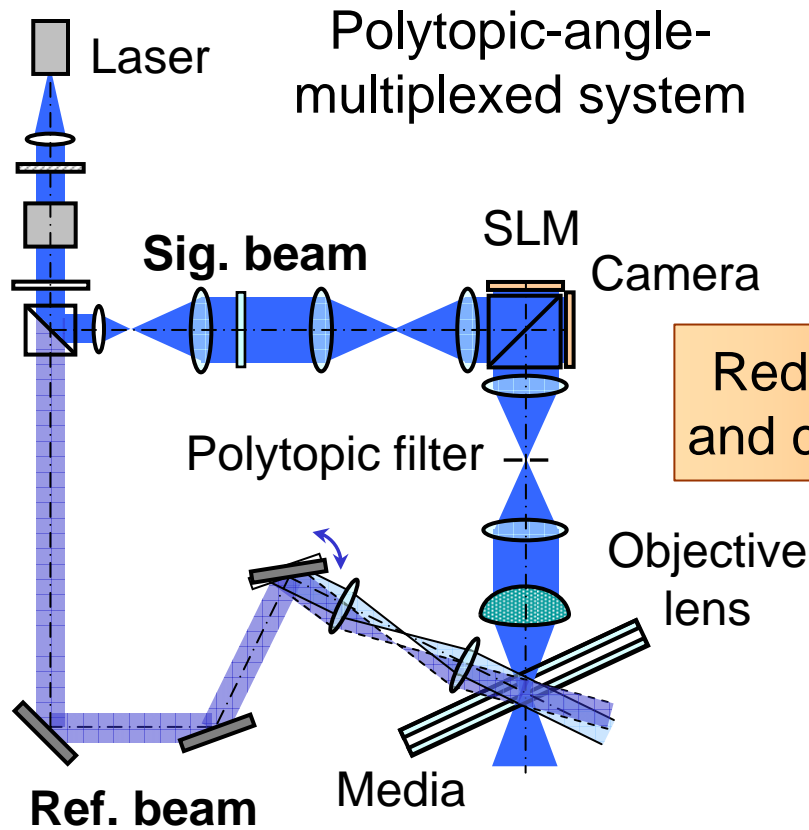

(b) Consumer system

## Monocular architecture<sup>[1]</sup>

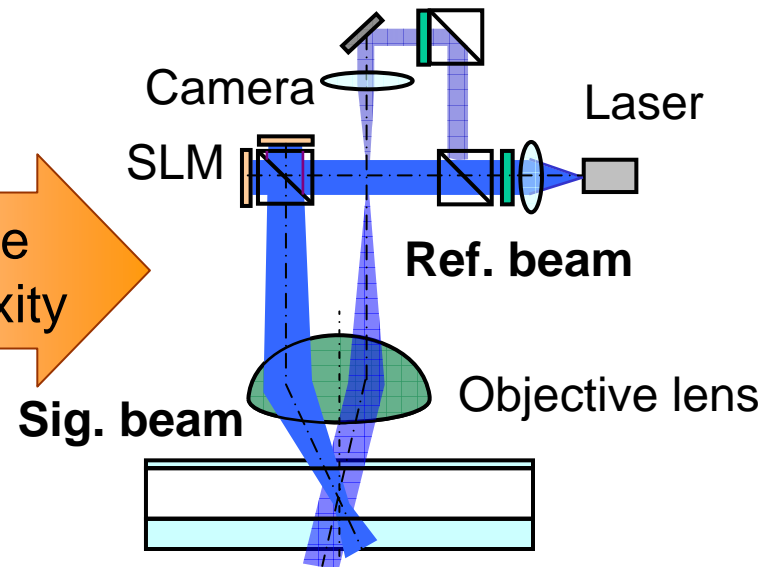

Reduce size  
and complexity

[1] TuC2 "High density recording using Monocular architecture for 500GB consumer system"

# 1.2 Necessity of Margin Allocation

Many factors which affect signal quality

## Example of factors

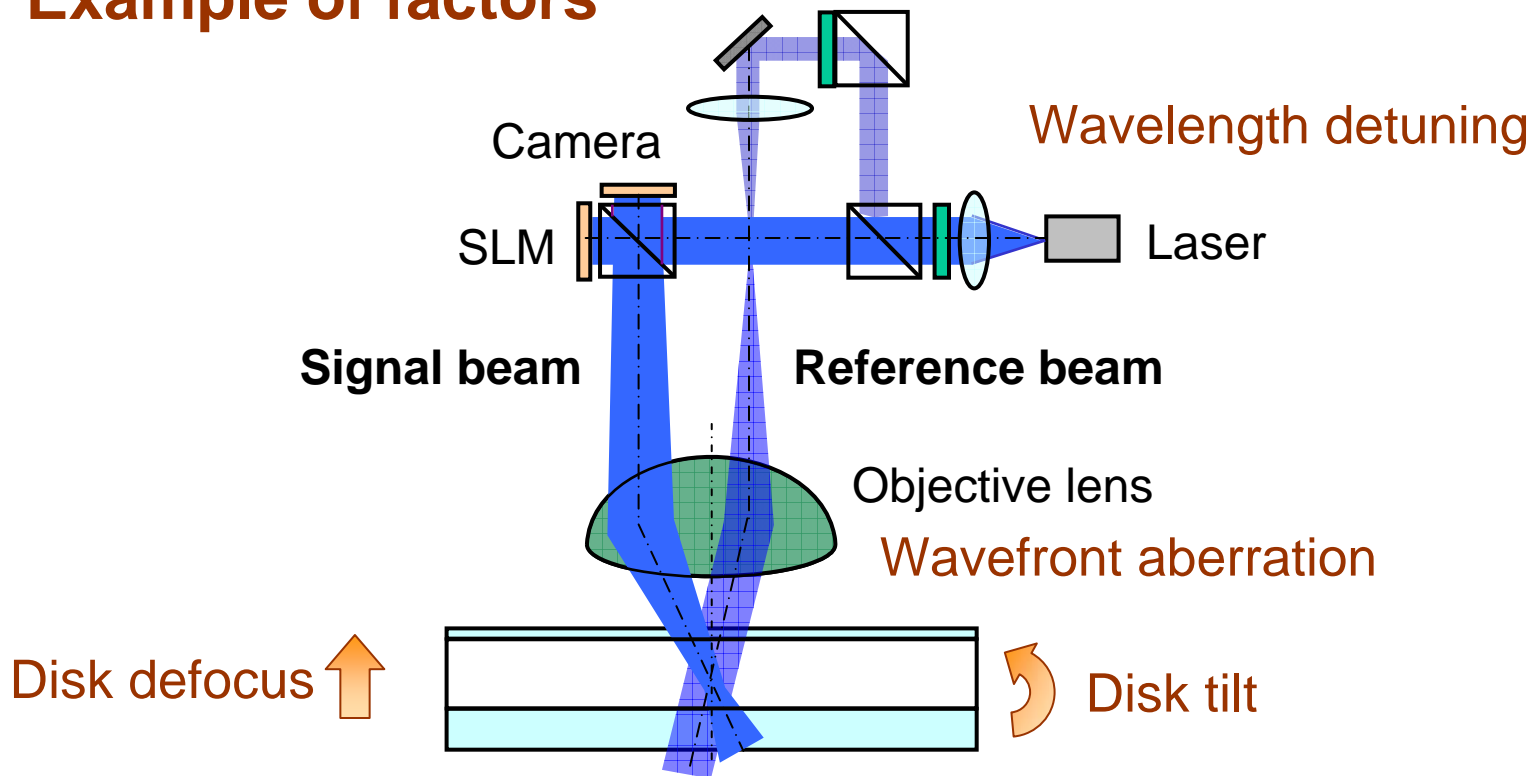

**Margin allocation is necessary to figure out the technical difficulty for product design**

# 1.3 Flow of Margin Allocation

(a **Determine the limit**  
)

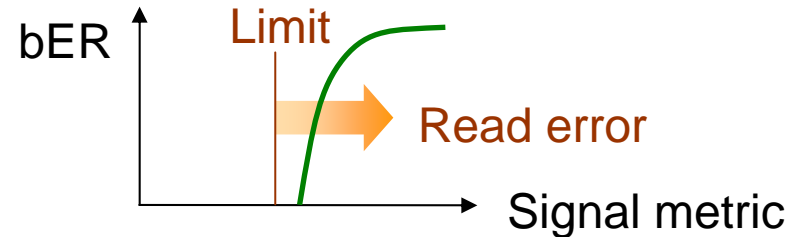

(b **Measure tolerance**  
)

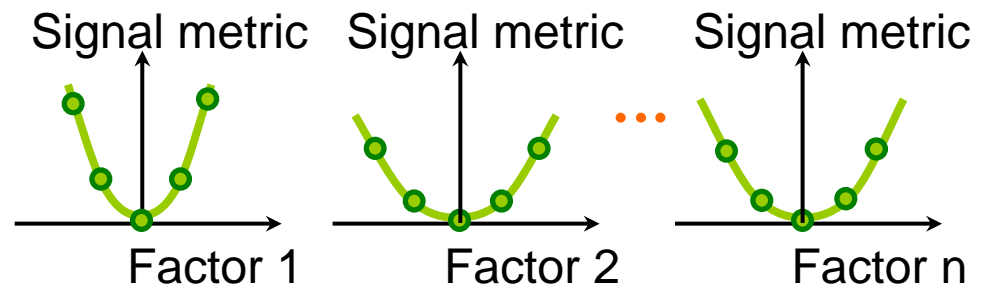

(c **Allocate margin**

considering multiple stresses are applied simultaneously

Factor	Margin	Signal metric
Factor 1 ( Wavelength )	. . .	. . .
Factor 2 ( Defocus )	. . .	. . .
Factor 3 ( Tilt )	. . .	. . .
. . .	. . .	. . .
<b>Total signal quality</b>		. . . <b>Within the limit</b>

# 1.4 Purpose

**To allocate margin for 500GB holographic memory system using Monocular architecture**

**To establish new metric and margin allocation technique for page based holographic memory system**

1. Introduction
- 2. Requirements to signal metric**
3. Experimental setup
4. Results
5. Conclusion

# 2.1 Jitter - Metric of Traditional ODD

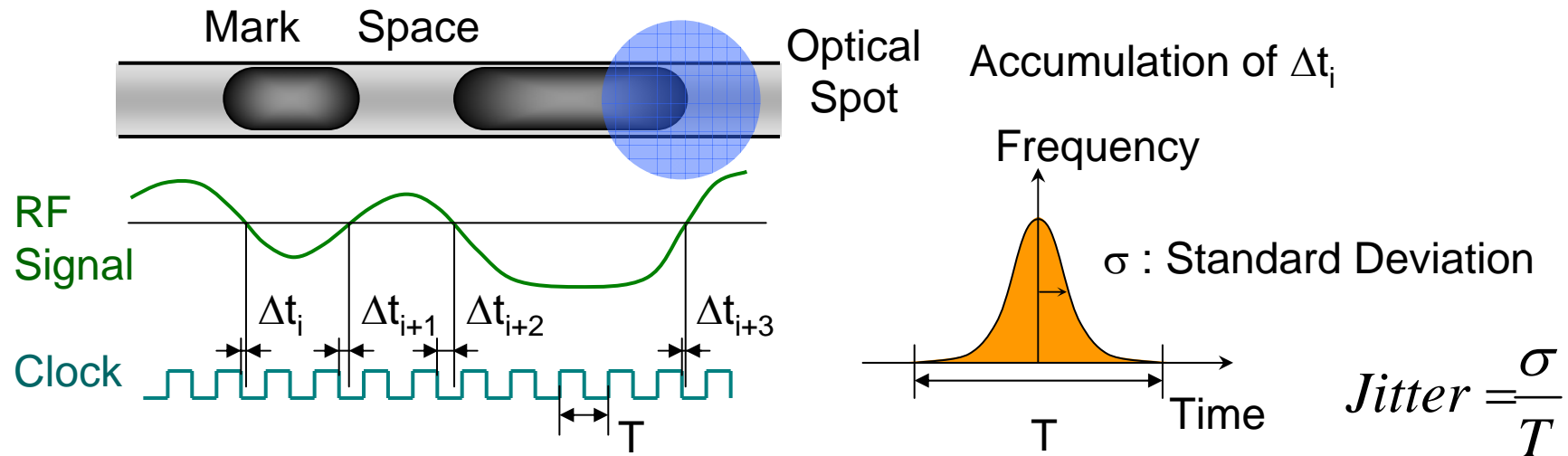

## Requirements to metric for margin allocation

1) High relationship with signal quality

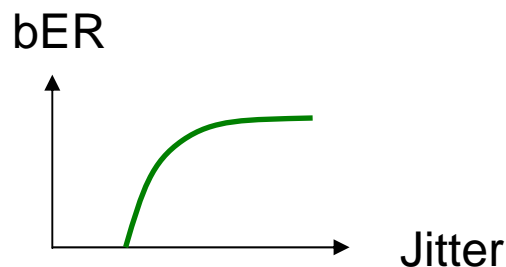

2) Additivity of metrics

$$\sigma = \sqrt{\sigma_0^2 + \sum_{i=1}^n \sigma_i^2}$$

$\sigma_0$  : DC jitter  
 $\sigma_i$  : Individual jitter

Total jitter      RSS of individual jitters  
(RSS : Root Sum Square)

# 2.2 Normalized Noise - New Metric

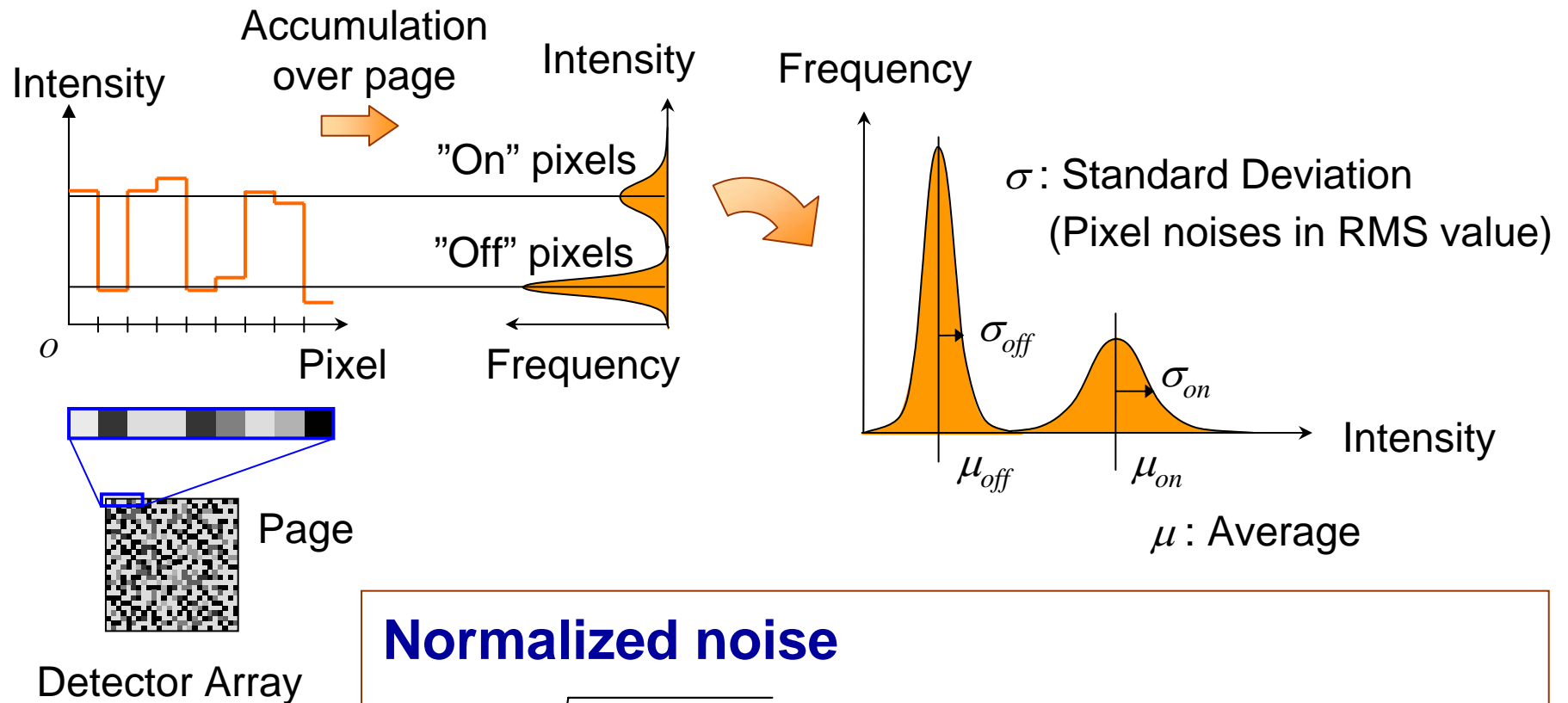

## Normalized noise

$$\sigma' = \frac{\sqrt{\sigma_{on}^2 + \sigma_{off}^2}}{\mu_{on} - \mu_{off}}$$

..... Pixel noise (RSS of  $\sigma_{on}$  and  $\sigma_{off}$ )

..... Signal amplitude

Same concept as the jitter

**Satisfy requirements for margin allocation**

# 2.3 Unique Noise and Total Noise

Subtraction DC noise by RSS  $\Rightarrow$  **Unique Noise**

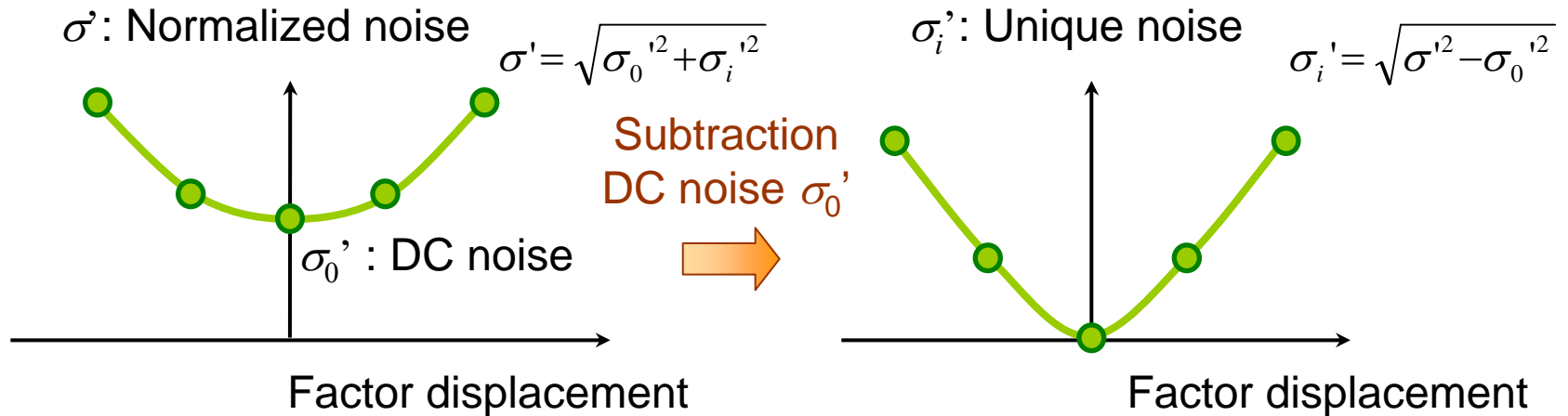

Addition unique noises by RSS  $\Rightarrow$  **Total Noise**

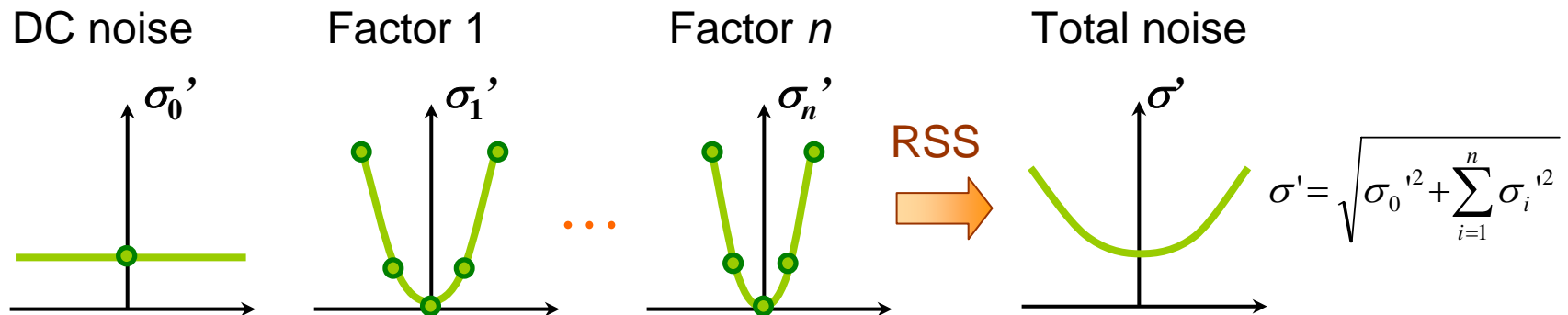

1. Introduction
2. Requirements to signal metric
- 3. Experimental setup**
4. Results
5. Conclusion

# 3.1 Experimental Setup

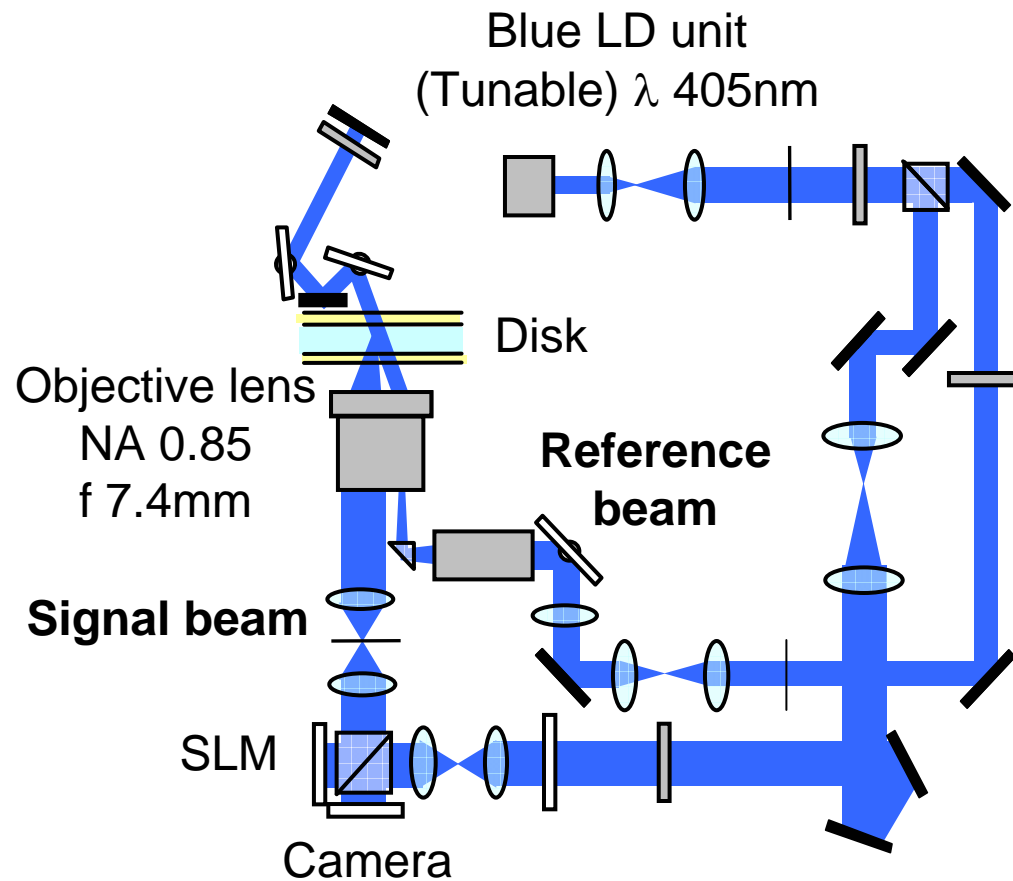

## Monocular architecture

### Recording condition

**500GB/disk**

( Coding rate : 0.488 )  
12cm disk

610Gbits/inch<sup>2</sup>

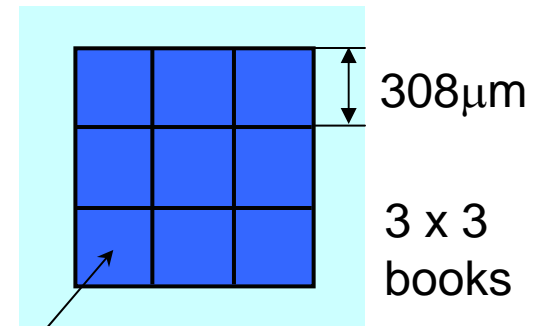

Book Page

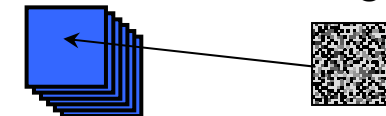

112 pages 100,676 bytes (raw)

## 3.2 Main Tolerance

### Selected main factors which significantly affect signal quality

Reference beam angle displacement

Disk tilt ( Bragg direction, Radial )

Detrack ( Tangential, Radial )

Defocus ( Disk, Camera )

Wavelength detuning

Temperature

Wavefront aberration

### Tolerance measurement

Recorded in the optimum condition

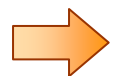

Reproduced with each stress applied

1. Introduction
2. Requirements to signal metric
3. Experimental setup
- 4. Results**
  - 4.1 Limit of Normalized Noise
  - 4.2 Tolerances
  - 4.3 Margin Allocation
5. Conclusion

# 4.1 Limit of Normalized Noise

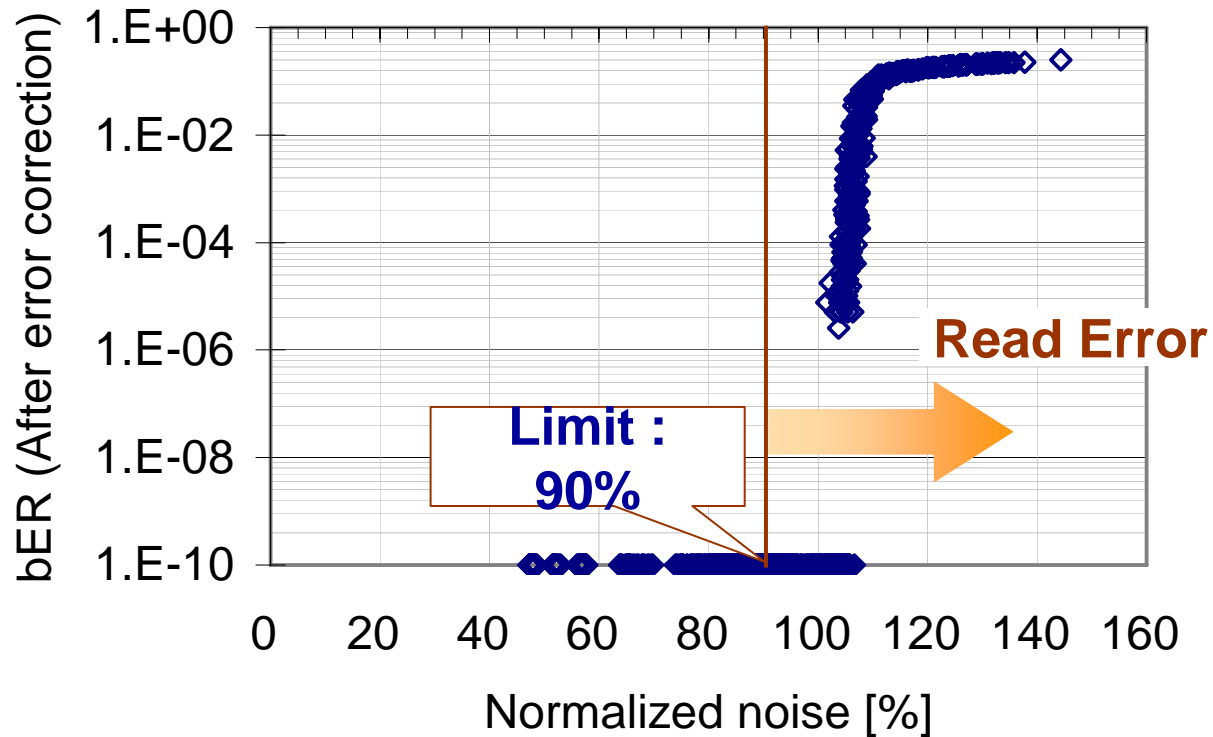

**Limit of the normalized noise was determined as 90%**

## 4.2 Tolerance

	Margin	Unique noise
Under optimum condition (DC noise)	-	
Reference beam angle displacement	[deg]	
Disk tilt in Bragg direction	[deg]	
Disk tilt in radial direction	[deg]	
Tangential detrack	[ $\mu\text{m}$ ]	
Radial detrack	[ $\mu\text{m}$ ]	
Disk defocus	[ $\mu\text{m}$ ]	
Camera defocus	[ $\mu\text{m}$ ]	
Wavelength detuning	[nm]	
Temperature	[ $^{\circ}\text{C}$ ]	
Wavefront aberration (rms)	[ $\lambda$ ]	
Total	-	Within 90%

**Measure tolerance and determine the margin for each factor**

## 4.2 Tolerance -Reference beam angle displacement

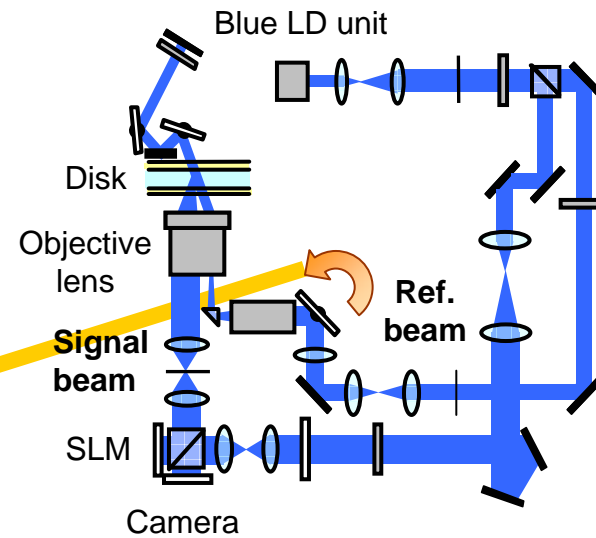
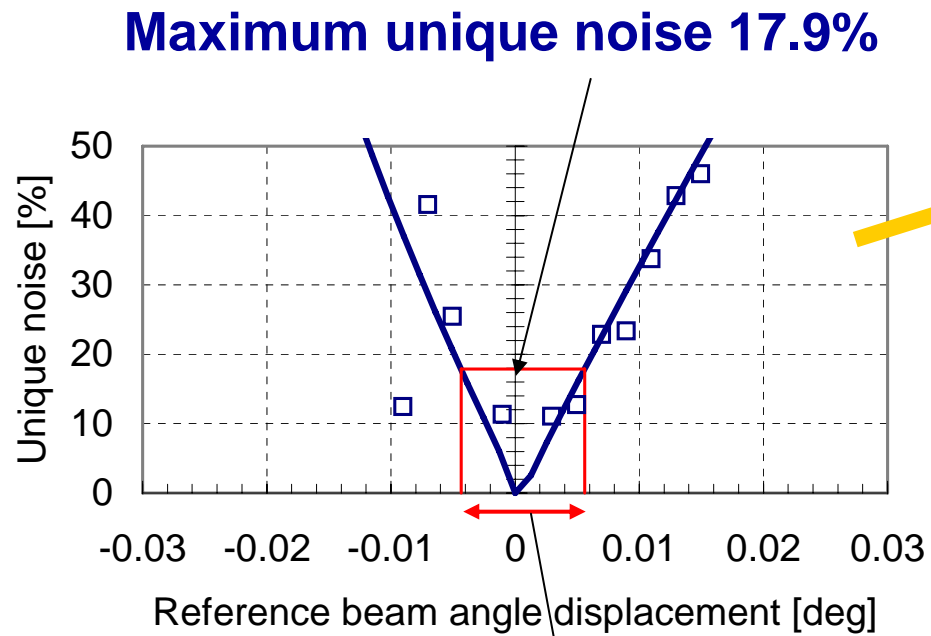

**Allocated margin  $\pm 0.0050\text{deg}$**

# 4.2 Tolerance -Disk tilt (Bragg direction, Radial)

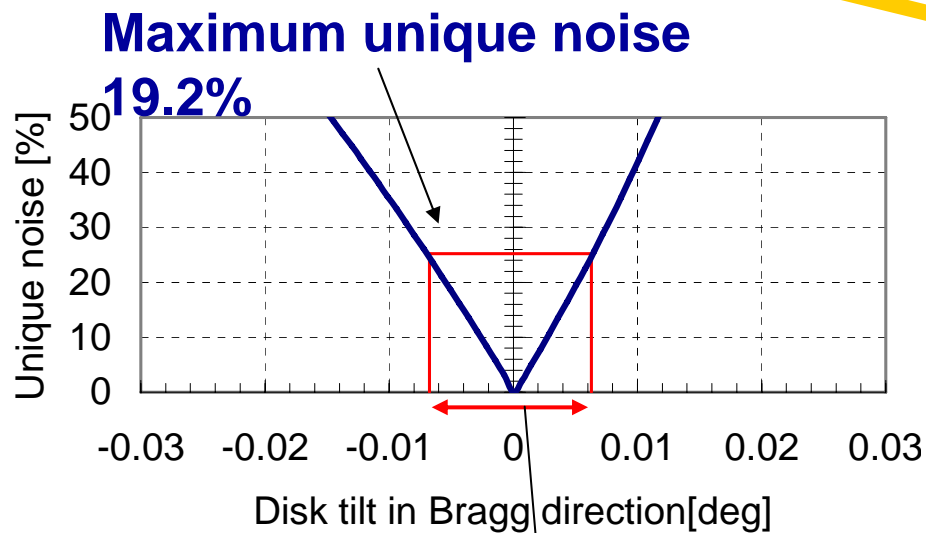
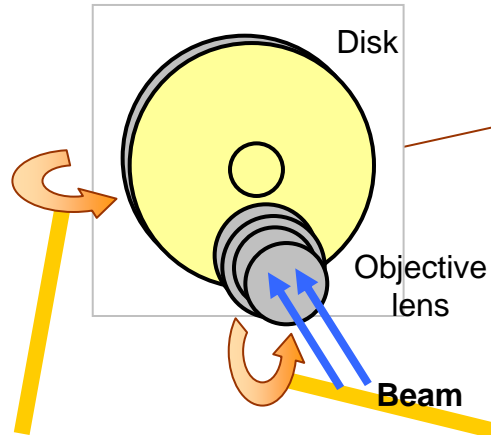
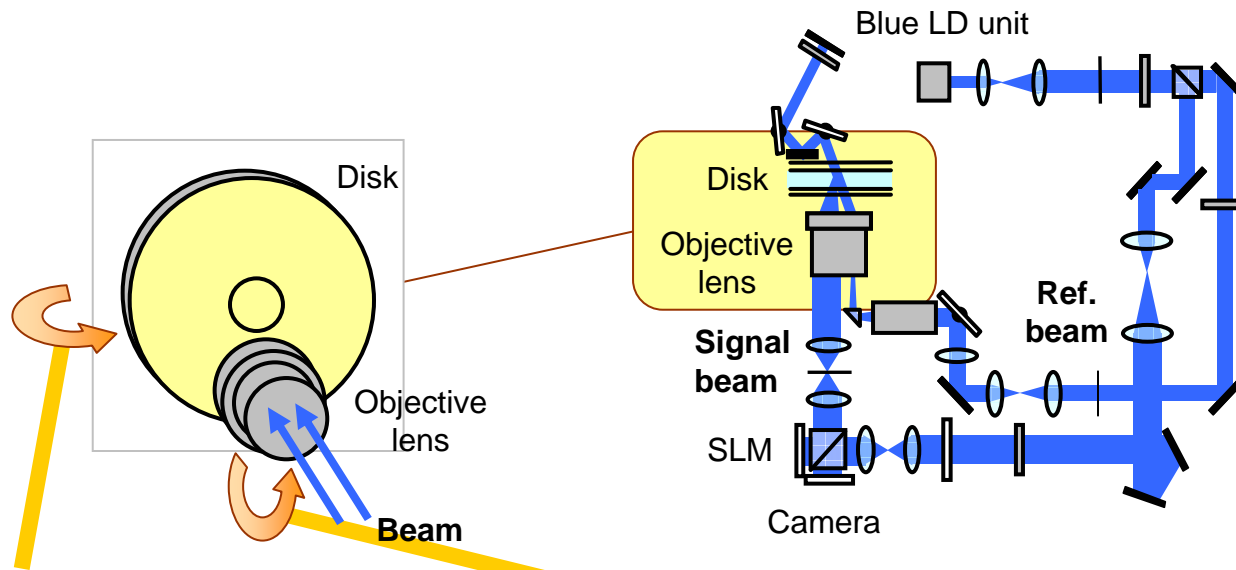

**Allocated margin**  
 **$\pm 0.0050\text{deg}$**

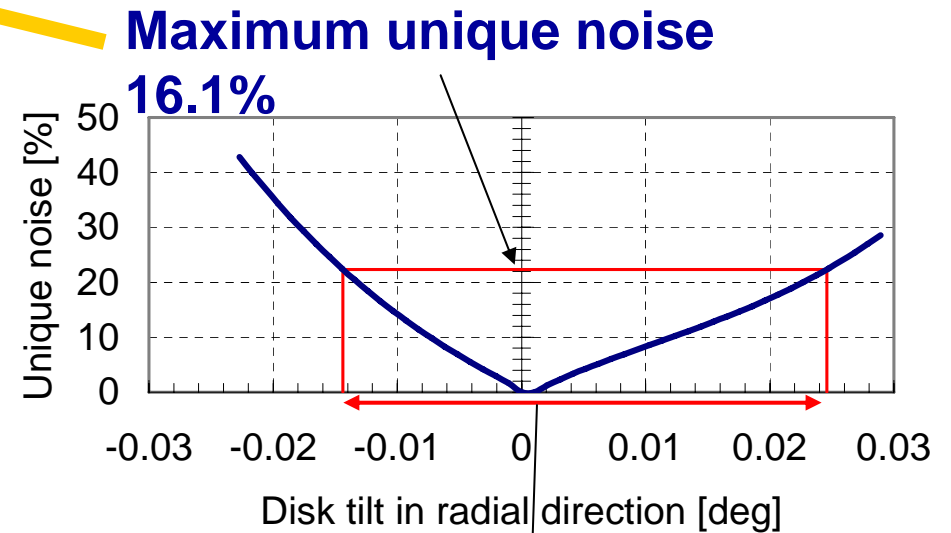

**Allocated margin**  
 **$\pm 0.0150\text{deg}$**

# 4.2 Tolerance -Detrack ( Tangential, Radial )

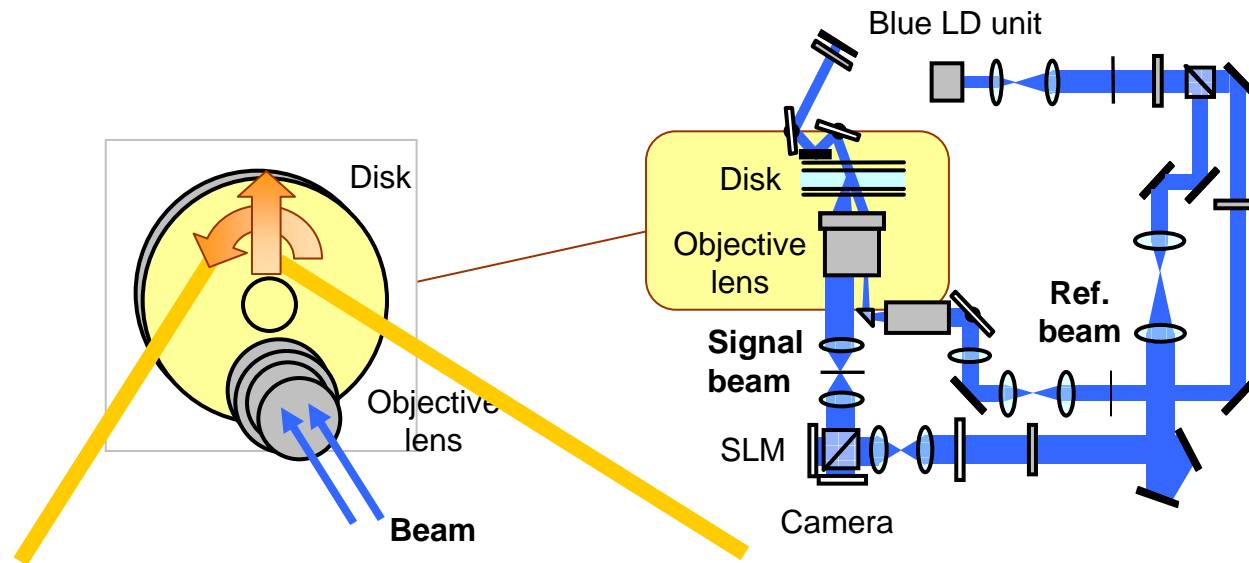

**Maximum unique noise**

**8.6%**

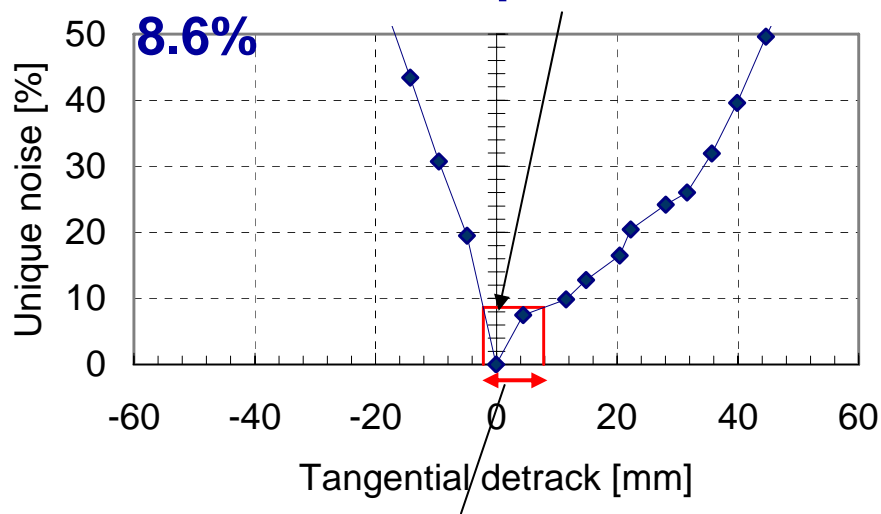

**Allocated margin  $\pm 5.0\mu\text{m}$**

**Maximum unique noise**

**9.1%**

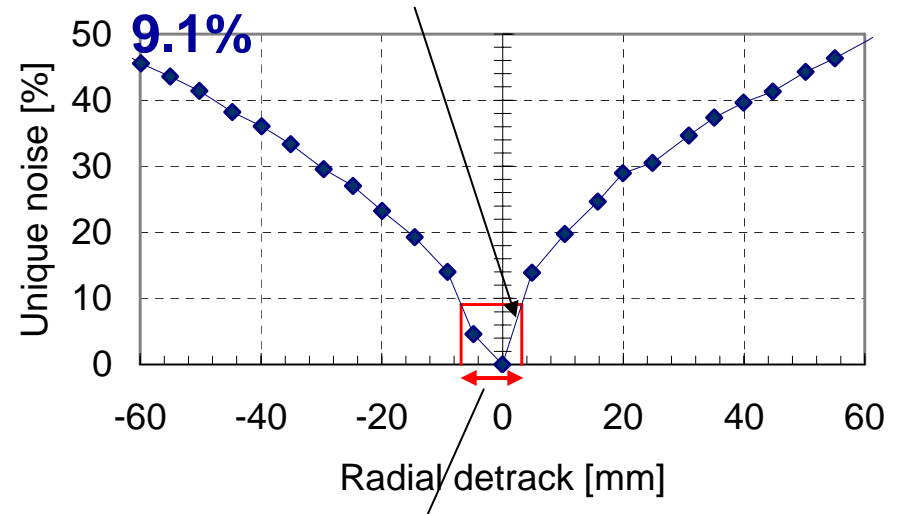

**Allocated margin  $\pm 5.0\mu\text{m}$**

# 4.2 Tolerance -Defocus ( Disk, Camera )

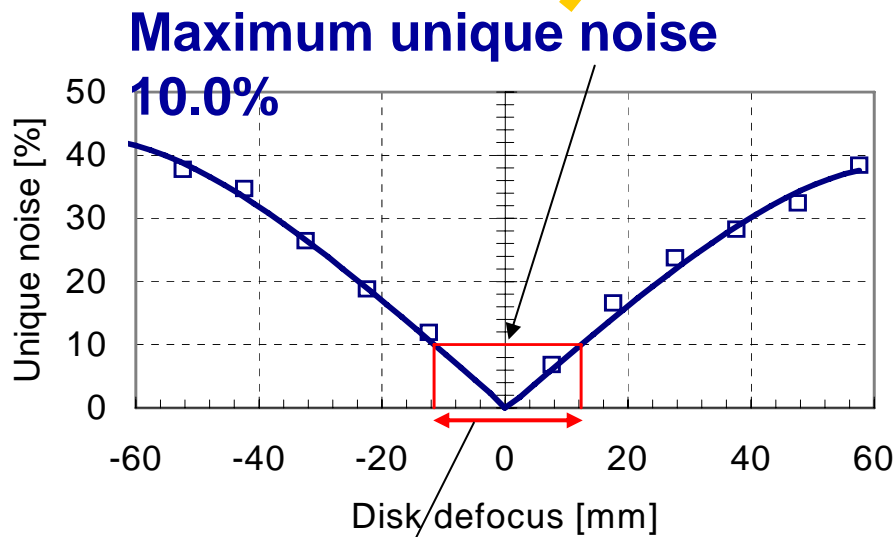
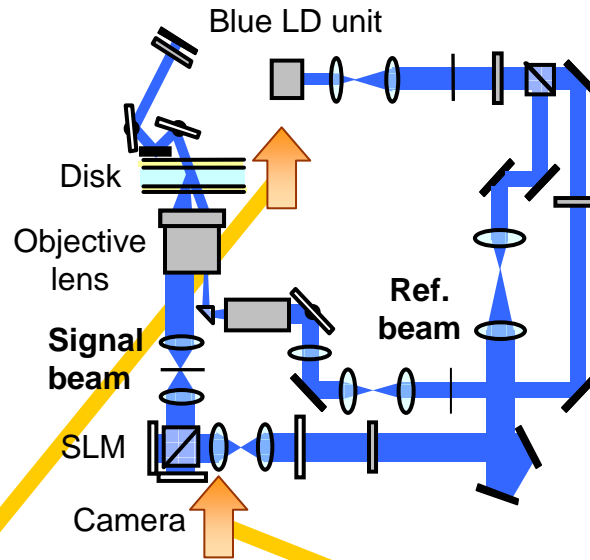

**Allocated margin  $\pm 12.0\mu\text{m}$**

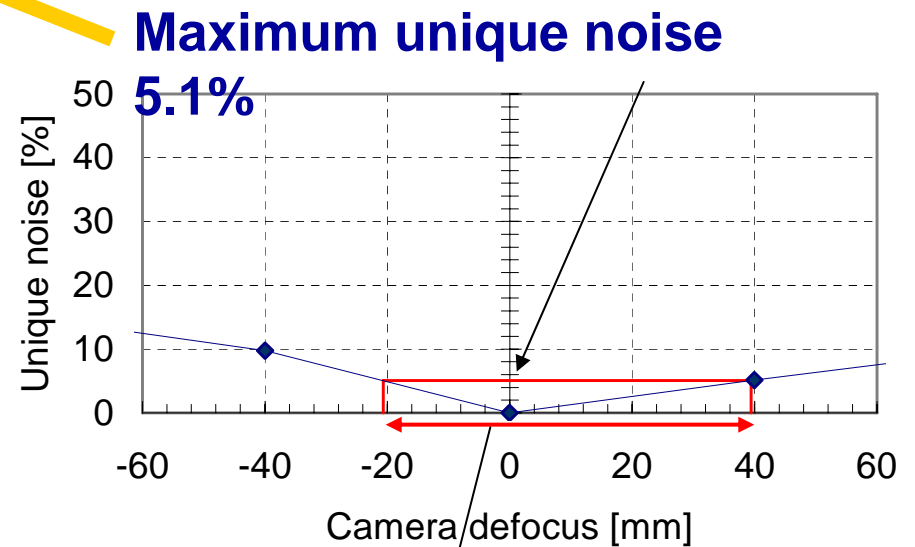

**Allocated margin  $\pm 30.0\mu\text{m}$**

# 4.2 Tolerance -Wavelength detuning and Temperature

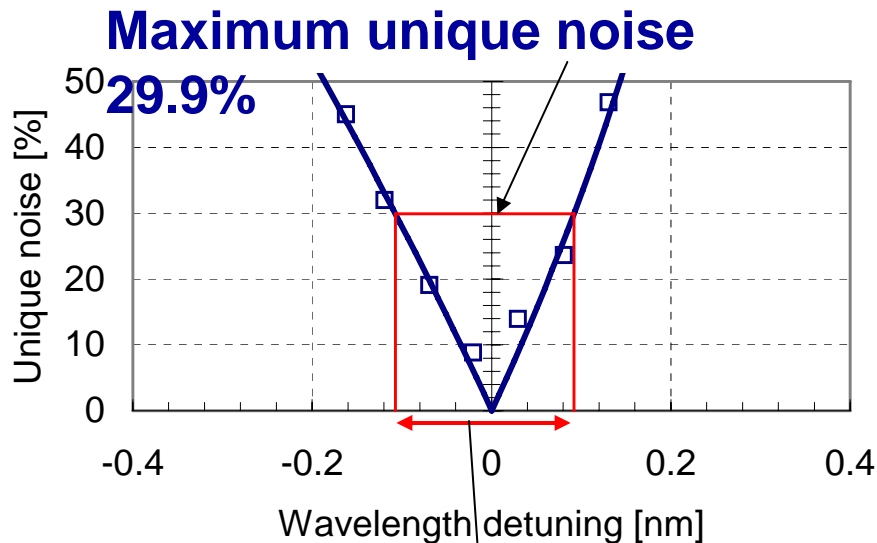
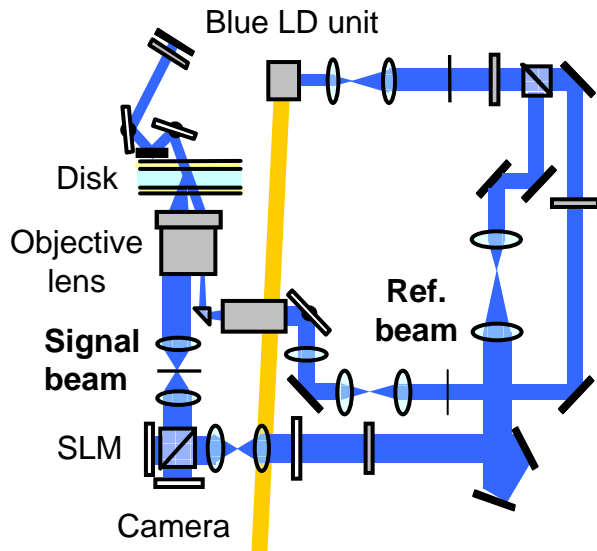

**Allocated margin  $\pm 0.100\text{nm}$**

Exceptionally simulated result

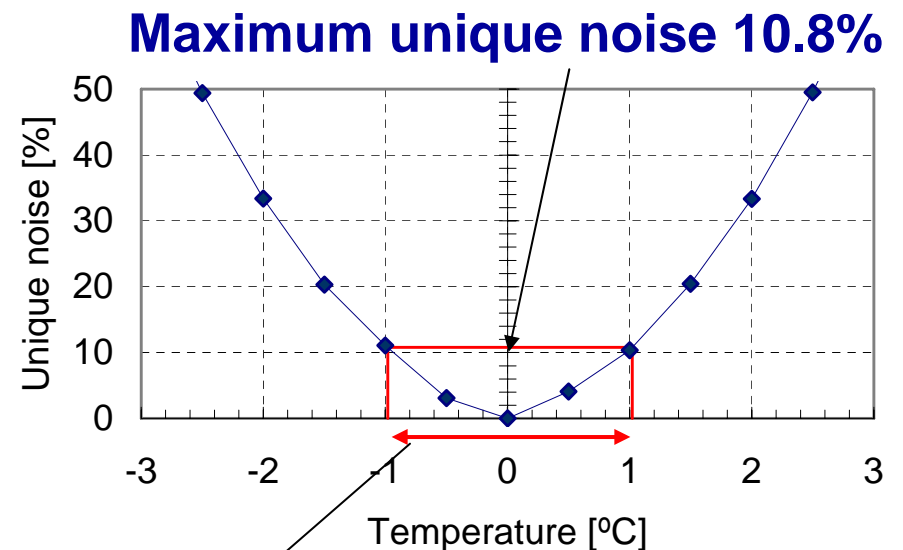

**Allocated margin  $\pm 1.0\text{ °C}$**

## 4.2 Tolerance -Wavefront aberration

Reproduced with phase plates  
which have various aberrations

**Maximum unique noise 14.2%**

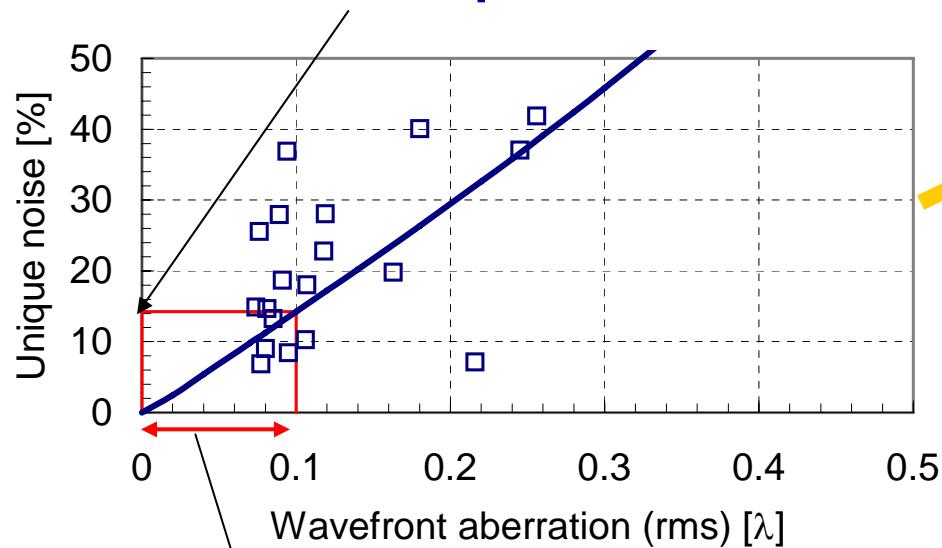

**Allocated margin  $\pm 0.1\lambda$**

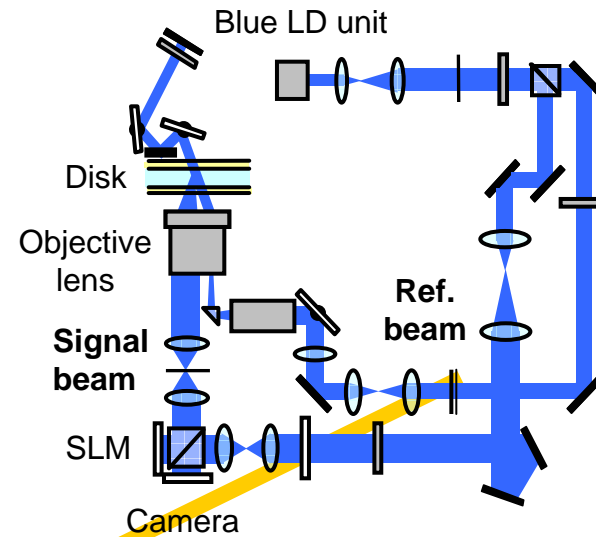

# 4.3 Margin Allocation Result

	Margin	Unique noise [%]	BD margin
Under optimum condition (DC noise)	-	$\sigma_0$ 75.0	
Reference beam angle displacement	$\pm 0.0050$ [deg]	$\sigma_1$ 17.9	
Disk tilt in Bragg direction	$\pm 0.0050$ [deg]	$\sigma_2$ 19.2	$\pm 0.2$ deg
Disk tilt in radial direction	$\pm 0.0150$ [deg]	$\sigma_3$ 16.1	$\pm 0.1$ deg
Tangential detrack	$\pm 5.0$ [ $\mu\text{m}$ ]	$\sigma_4$ 8.6	
Radial detrack	$\pm 5.0$ [ $\mu\text{m}$ ]	$\sigma_5$ 9.1	
Disk defocus	$\pm 12.0$ [ $\mu\text{m}$ ]	$\sigma_6$ 10.0	
Camera defocus	$\pm 30.0$ [ $\mu\text{m}$ ]	$\sigma_7$ 5.1	
Wavelength detuning	$\pm 0.100$ [nm]	$\sigma_8$ 29.9	
Temperature	$\pm 1.00$ [ $^{\circ}\text{C}$ ]	$\sigma_9$ 10.8	$\pm 25$ $^{\circ}\text{C}$
Wavefront aberration (rms)	0.100 [ $\lambda$ ]	$\sigma_{10}$ 14.2	
Total	-	RSS 89.8 <i>Within the limit</i>	

**Tighter than traditional ODD,  
but can be controlled with wobble servo technique**

# 4.3 Wobble Servo Technique

Mark R. Ayres, et al, "Wobble alignment for angularly multiplexed holograms,"  
Tech. Digest of ISOM/ODS'08, ThC.

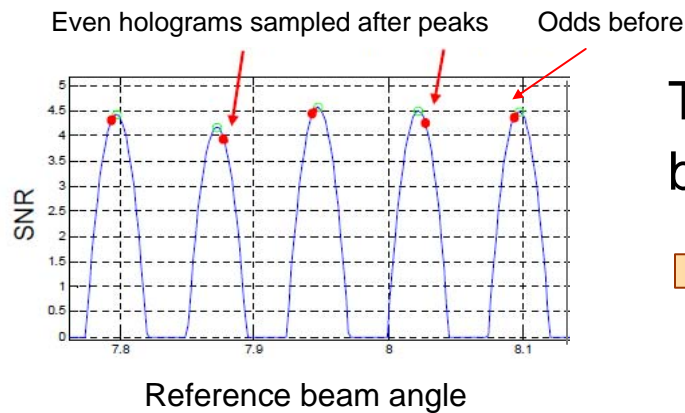

Track hologram angle during read-out by introducing a small alternating angle offset

➡ **Disk tilt in Bragg control**

Disk tilt in radial (pitch) causes horizontal shift of intensity centroid

➡ **Disk tilt in radial control**

Wavelength detuning causes vertical shift of intensity centroid

➡ **Wavelength/Temperature control**

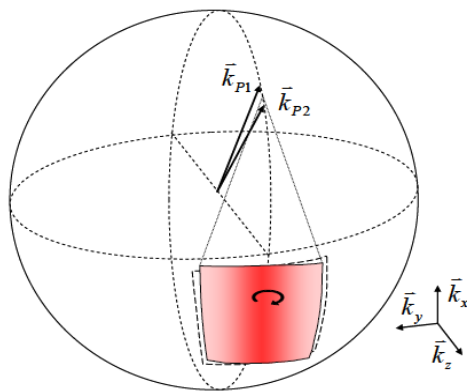

1. Introduction
2. Requirements to signal metric
3. Experimental setup
4. Results
- 5. Conclusion**

# 5. Conclusion

A new signal quality metric called normalized noise and a novel margin allocation technique were developed.

 **Useful for product design  
in page based holographic memory system**

Margin allocation for 500GB holographic memory system using Monocular architecture was performed.

 **Each designed margin is realistic and achievable.**